

Aisle width (unit: mm) Pallet length: L, Pallet width: W *The table below indicates the value during AWC (small turn radius control) *Stacking Mode*

Model	Type	Mast	Battery	Intersecting (IA) and Right-angle aisle width					Right-angle stacking (SA) aisle width *1							
				L	800	1,000	1,000	1,000	1,100	800	1,000	1,000	1,000	1,100		
1.0 ton	8FBR10 S(J)XII	type S Front (side)	Standard/Semi-free	201 (front)	1,550	1,560	1,570	1,610	1,570	2,060	2,210	2,230	2,250	2,320		
				201 (side), 260	1,550	1,560	1,570	1,610	1,570	2,070	2,220	2,240	2,270	2,330		
				280-370	1,560	1,560	1,570	1,610	1,580	2,130	2,290	2,310	2,330	2,400		
				2-stage full-free	201, 260	1,560	1,560	1,570	1,610	1,580	2,100	2,250	2,270	2,290	2,360	
					280-370	1,560	1,560	1,570	1,610	1,580	2,160	2,320	2,330	2,360	2,430	
					201, 260	1,560	1,560	1,570	1,610	1,580	2,100	2,250	2,270	2,290	2,360	
3-stage full-free	280-370	1,560	1,560	1,570	1,620	1,580	2,160	2,320	2,330	2,360	2,430					
	201 (front)	1,630	1,630	1,640	1,690	1,650	2,060	2,210	2,230	2,260	2,320					
	201 (side), 260	1,630	1,630	1,640	1,690	1,650	2,070	2,220	2,240	2,270	2,330					
1.25 ton	8FBR13 S(J)XII	type S Front (side)	Standard/Semi-free	201 (front)	1,630	1,630	1,640	1,690	1,650	2,070	2,220	2,240	2,270	2,330		
				201 (side), 260	1,630	1,630	1,640	1,690	1,650	2,070	2,220	2,240	2,270	2,330		
				280-370	1,640	1,640	1,650	1,690	1,650	2,140	2,290	2,310	2,330	2,400		
				2-stage full-free	201, 260	1,640	1,640	1,650	1,690	1,660	2,160	2,320	2,330	2,360	2,430	
					280-370	1,640	1,640	1,650	1,690	1,660	2,160	2,320	2,330	2,360	2,430	
					201, 260	1,640	1,640	1,650	1,690	1,650	2,100	2,250	2,270	2,290	2,360	
3-stage full-free	280-370	1,640	1,640	1,650	1,690	1,660	2,160	2,320	2,330	2,360	2,430					
	201 (front)	1,630	1,630	1,640	1,690	1,650	2,060	2,210	2,230	2,260	2,320					
	201 (side), 260	1,630	1,630	1,640	1,690	1,650	2,070	2,220	2,240	2,270	2,330					
1.35 ton	8FBR14 S(J)XII	type S Front (side)	Standard/Semi-free	201 (front)	1,630	1,630	1,640	1,690	1,650	2,070	2,220	2,240	2,270	2,330		
				201 (side), 260	1,630	1,630	1,640	1,690	1,650	2,070	2,220	2,240	2,270	2,330		
				280-370	1,640	1,640	1,650	1,690	1,650	2,140	2,290	2,310	2,330	2,400		
				2-stage full-free	201, 260	1,640	1,640	1,650	1,690	1,660	2,160	2,320	2,330	2,360	2,430	
					280-370	1,640	1,640	1,650	1,690	1,660	2,160	2,320	2,330	2,360	2,430	
					201, 260	1,640	1,640	1,650	1,690	1,650	2,100	2,250	2,270	2,290	2,360	
3-stage full-free	280-370	1,640	1,640	1,650	1,690	1,660	2,160	2,320	2,330	2,360	2,430					
	201 (front)	1,630	1,630	1,640	1,690	1,650	2,060	2,210	2,230	2,260	2,320					
	201 (side), 260	1,630	1,630	1,640	1,690	1,650	2,070	2,220	2,240	2,270	2,330					
1.5 ton	8FBR15 C(J)XII	type C Front (side)	Standard/Semi-free	260	1,690	1,690	1,700	1,740	1,700	2,090	2,230	2,250	2,280	2,340		
				Full-free	260	1,690	1,690	1,700	1,740	1,700	2,100	2,250	2,270	2,300	2,360	
				3-stage full-free	260	1,690	1,690	1,700	1,740	1,700	2,100	2,250	2,270	2,300	2,360	
	8FBR15 S(J)XII	type S Front (side)	Standard/Semi-free	280-370	1,690	1,690	1,700	1,740	1,700	2,140	2,290	2,310	2,330	2,400		
				2-stage full-free	280-370	1,690	1,690	1,700	1,740	1,710	2,160	2,320	2,330	2,360	2,430	
				3-stage full-free	280-370	1,690	1,690	1,700	1,740	1,710	2,160	2,320	2,330	2,360	2,430	
8FBR15 A(J)XII	type A Front (side)	Standard/Semi-free	280-370	1,800	1,790	1,800	1,840	1,810	2,140	2,290	2,310	2,340	2,400			
			2-stage full-free	280-370	1,800	1,790	1,800	1,850	1,810	2,190	2,360	2,370	2,390	2,470		
			3-stage full-free	280-370	1,800	1,790	1,800	1,850	1,810	2,190	2,360	2,370	2,390	2,470		
8FBR15 W(J)XII	type W Front (side)	3-stage full-free	280-370	1,850	1,850	1,850	1,870	1,860	2,190	2,360	2,370	2,390	2,470			
			8FBR18 S(J)XII	type S Front (side)	Standard/Semi-free	280-370	1,800	1,790	1,800	1,840	1,810	2,140	2,290	2,310	2,340	2,400
						2-stage full-free	280-370	1,800	1,790	1,800	1,850	1,810	2,190	2,360	2,370	2,390
3-stage full-free	280-370	1,800				1,790	1,800	1,850	1,810	2,190	2,360	2,370	2,390	2,470		
8FBR18 A(J)XII	type A Front (side)	Standard/Semi-free	280-370	1,820	1,820	1,830	1,870	1,840	2,170	2,320	2,340	2,370	2,430			
			2-stage full-free	280-370	1,820	1,820	1,830	1,870	1,840	2,220	2,390	2,400	2,420	2,500		
			3-stage full-free	280-370	1,820	1,820	1,830	1,870	1,840	2,220	2,390	2,400	2,420	2,500		
8FBR18 W(J)XII	type W Front (side)	3-stage full-free	280-370	1,850	1,850	1,850	1,870	1,860	2,190	2,360	2,370	2,390	2,470			

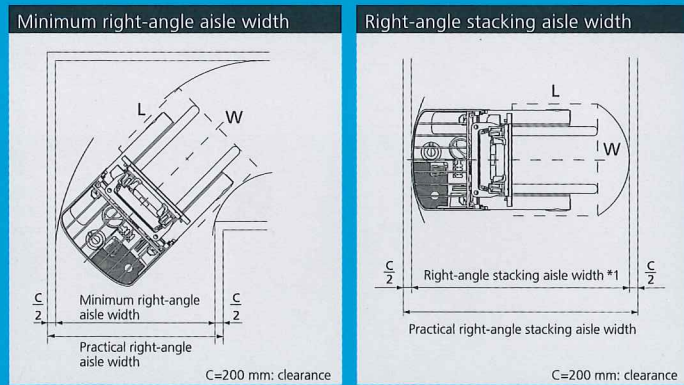

*1: Figure does not include the turning capacity of 200 mm in the practical right-angle stacking aisle width.

For the forklift driver operations, inspection and maintenance, always read the instruction manual and follow the instructions correctly.



SUMITOMO NACCO MATERIALS HANDLING SALES CO.,LTD.
2-18, Heiwajima 3-chome, Ota-ku, Tokyo, 143-0006 JAPAN
Phone: 81-3-6404-3262 Fax: 81-3-6404-3272

Manufactured by
SUMITOMO NACCO MATERIALS HANDLING CO.,LTD.
2-75, Daitoh-cho, Obu-shi, Aichi-ken, 474-8555 JAPAN
Phone: 81-562-48-5251 Fax: 81-562-48-5396

We offer personalized after service and looking forward to see you.

*The actual features and specifications may differ from those described in the catalog.
*The color of the photographs in this catalog may differ slightly from the actual color depending on the ink quality.

QuaPro-R

Electric Reach Forklift Trucks

1.0 TON — 1.8 TON

8FBR 10·13·14·15·18 S(J)XII
8FBR 15 C(J)XII
8FBR 15·18 A(J)XII
8FBR 15·18 W(J)XII

The 4 "PRO" in response to the customer's voice.
QuaPro-R has greatly advanced in load handling operations.

PROFESSIONAL
PRODUCTIVE
PROFITABLE
PROGRESSIVE



CODE
ER-01E

Intuitive operation with man-machine feeling

Materialized the manipulative feeling delicately reflecting the operator's mind.

Human Sensible



QuaPro-R design concept: Integration of human and machine.

The inching ability of the QuaPro-R during travel and load handling has been thoroughly revised to realize spontaneous operation in response to the operator's intentions. Moreover, operator-oriented vehicle manufacturing has been conducted for easy getting on and off by lowering the floor while maintaining good mast visibility. The integrated human-machine operation feel enhances load handling efficiency, and leads to overall productivity improvement. In addition, AWC (small turn radius control) is equipped to realize its key concept of a minimum turning diameter (minimum right-angle stacking aisle width). Selection to minimize 90-degree turning (stacking mode) during load handling can be performed freely.

The QuaPro-R pursues a comfortable operation feel that goes one step further.



1 The essential performance showing easy operating

Smooth manipulation feeling
The thorough review of the inching for loading and unloading operation

The characteristics of driving acceleration

Materialized the comfortable maneuver in streamlining all aspects of the speed ranging from low to high.

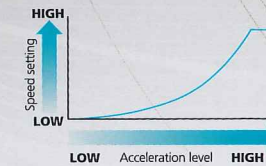

The characteristics of driving acceleration

Improved the maneuverability in low and medium speed range; the modest speed in inching operation like setting a delicate position, quick for an agile start.

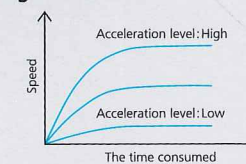

Inching performance for loading and unloading

Changed the characteristics for more delicate operation by widening the low-speed range of the lift valve. Also, changed the loading and unloading motor from DC to AC use. The change made both good response and easy inching compatible by optimizing the start control of the motor.



2 The essential performance showing easy operating

Maneuvering in shorter radius and staying still
"AWC (small turn radius control)" Patented

Sumitomo's patented technology Aisle Width Control (AWC/small turn radius control), making an expert's circling technique possible for anybody. The operator could easily work without cutting off the steering in turning for larger room available by AWC.

→ The detailed explanation on page 06.

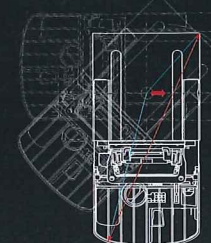

3 The essential performance showing easy operating

Reduction of uncomfortable vibration during travel
Low vibration suspension system

→ Please refer to the page 07 for the detail.

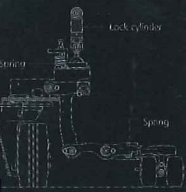

4 The essential performance showing easy operating

Reduces fatigue during getting on and off
Lowered floor

→ Please refer to the page 08 for the detail.

QuaPro-R
Electric Reach Forklift Trucks

Energy Saving

Eco-friendly energy conservation

Power consumption cost reduced **24%** compared to previous models.

(* Value is for 8FBR15C. 8FBR15S achieved 25%.)

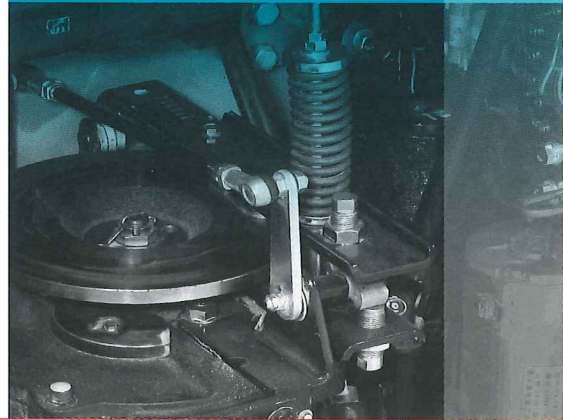

QuaPro-R design concept: Energy saving
 QuaPro-R is the first reach-type forklift model to adopt **IPM motor** which is a drive motor. In addition, we pursued thorough high efficiency, such as revising adopted parts like the AC motor for load handling operations, reducing the vehicle weight, and optimizing the layout of devices and each type of control. Low power consumption level that tops the industry has been achieved (compared to our previous models: 24% decrease). Reductions in power consumption cost (24% decrease) and CO₂ emissions (356 kg decrease/year), and prolong of operating hours (+approx. 2 h/day) are realized. Together with the improved efficiency of the working environment, we will offer our customers an eco-friendly materials handling environment. [*8FBR15C model]



[Photo: 8FBR15C/forklift with high-back support]



Energy Conserving Machinery Award
 The Japan Machinery Federation
 Presidential Award
 for the year 2012: The Japan Machinery Federation

Awarded: Excellent Energy Conserving Machinery / The Japan Machinery Federation Presidential Award
 The Excellent Energy Conserving Machinery Award is the awarding system established in 1980 by general incorporated association of The Japan Machinery Federation, to encourage and promote the development and dissemination of an outstanding energy conserving machinery. The award system has been consecutively carried out to date. Our firm was awarded The Japan Machinery Federation Presidential Awards for the contribution to the promotion of effective energy use through the development of QuaPro-R that achieved overwhelming energy saving.



Long Time Long Life

"Long Time Long Life" is the key-catch-phrase, derived from our policy, aiming at developing and sales of the forklift. The representing concept of the catch means the machine is capable of being operated for a longer time and more durable than conventional ones. (However, the catch does not necessarily express the lawful guarantee of product's life span and performance.)

8FBR15S (280Ah)	8FBR15C (260Ah)	Previous in-company models
-371	-356	0

Reduction of CO₂ emission amount

The calculation of the CO₂ emission amount is based on the new and old models performing the same operations (operational limit of workload for previous vehicles). (The CO₂ conversion coefficient value is used by Tokyo Electric Power Company according to emission coefficients for each electric power supplier by the Ministry of the Environment in 2010.)

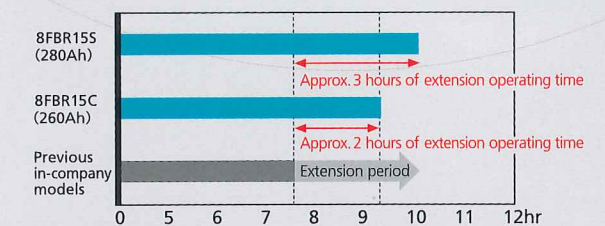

Reduction of power consumption cost

A reduction in power consumption cost of 24% compared to our previous models has been achieved by reducing power consumption.

[*8FBR15C model]
 (JIS D6202:2011 in-company test value occurring in operation cycle pattern)

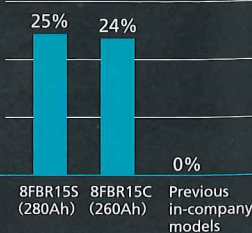

Reduction of CO₂ emission amount

Compared to our previous models, a reduction of 356 kg/year in CO₂ emissions is realized by reducing power consumption. The reduction in CO₂ emissions by the QuaPro-R contributes to our customer's environmental activities.

[*8FBR15C model]



Prolong of operating time

Prolong of approximately 2 hours in operating time compared to our previous models is realized by reducing power consumption. Auxiliary charging is reduced which provides advantages in various situations such as reductions in the entire operation time, or even continuous operation when unexpected additional work is required.

[*8FBR15C model]
 (JIS D6202:2011 in-company test value occurring in operation cycle pattern)

QuaPro-R
 Electric Reach Forklift Trucks



Smooth Turn

Smooth turning and small, facile turning radius

Minimum right-angle stacking aisle width of **2,340 mm** realized.

(Achievement of -130 mm compared to our previous models)

QuaPro-R design concept: Space saving
The mast structure, retracting range, and device layout have undergone major revisions while ensuring the wheel base and the cabin space of the previous. A minimum right-angle stacking aisle width of 2,340 mm (compared to our previous models: -130 mm) has been realized [*8FBR15C model].

The major improvement in turning radius performance realizes: the increase in productivity (in-company increase of 33%), decrease of fatigue levels (in-company decrease of 20%) due to turning operations, and increase of warehousing efficiency (in-company increase of 10%).

QuaPro-R supports our customers in greater efficiency of the logistics operations.



QuaPro-R
Electric Reach Forklift Trucks

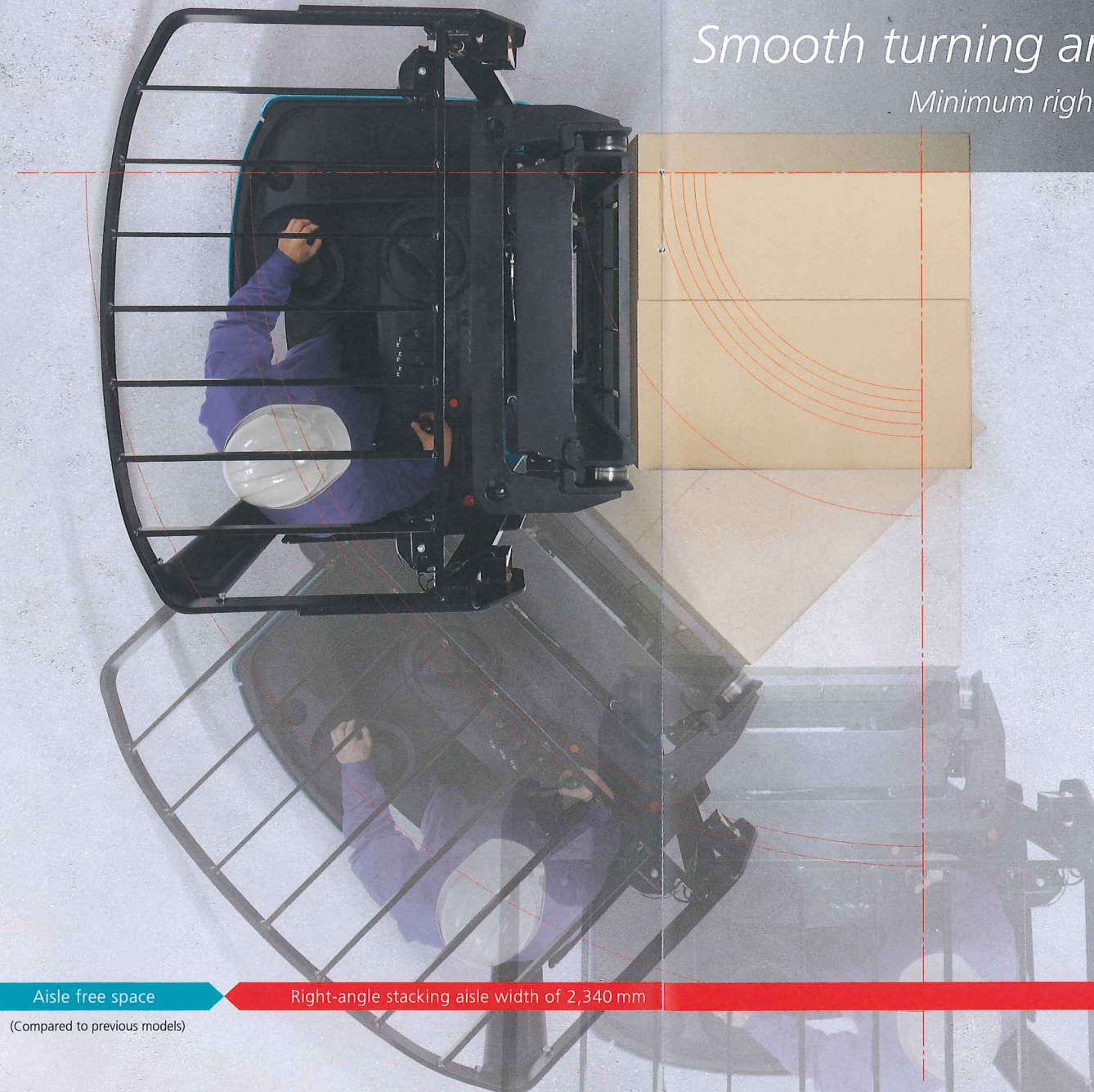

Aisle free space

(Compared to previous models)

Right-angle stacking aisle width of 2,340 mm

Previous in-company model use

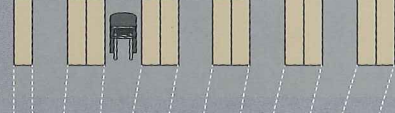

8FBR15C use

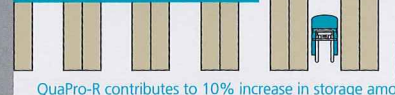

QuaPro-R contributes to 10% increase in storage amount

Image shows warehouse rack area comparison with new and old models

Warehouse/storage efficiency increase of 10%
(compared to our previous models)

The reduction in right-angle stacking aisle width enables better utilization of storage space in a warehouse. Increasing the number of rack is made possible by narrowing the aisle width which allows larger volume of storage.

[*8FBR15C model]
*30 m × 16 m warehouse assumed

8FBR15C (260Ah) Previous in-company models

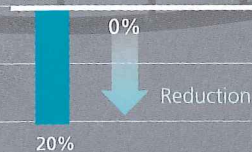

Reduction of fatigue levels

20%

Fatigue level reduction of 20%
(compared to our previous models)

The reduction in right-angle stacking aisle width largely reduce the steering-turn operations by the operator. Unnecessary operations are minimized to enable reduction of operator fatigue levels.

[*8FBR15C model] (JIS D6202:2011 in-company test value occurring in operation cycle pattern)

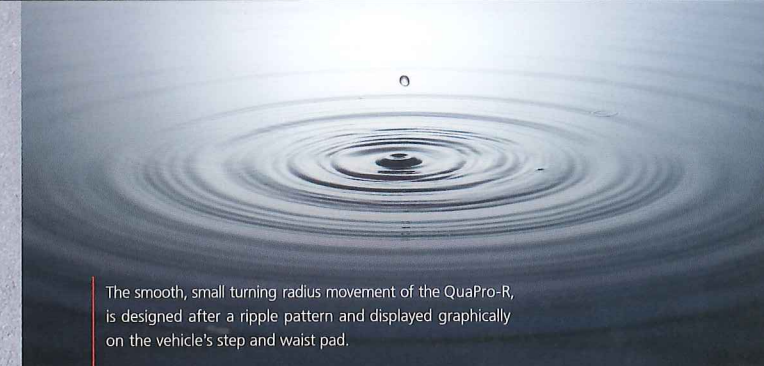

The smooth, small turning radius movement of the QuaPro-R, is designed after a ripple pattern and displayed graphically on the vehicle's step and waist pad.



Ripple Pattern

Patented Sumitomo's technology AWC (Aisle Width Control)

It is an important factor, to select a reach-type forklift, that with how short turning radius the machine could take. With the shorter radius, a warehouse operator could have higher stowage efficiency by narrowing the width of an aisle. Also, when the operator could not change the width, turning with comfortable room may contribute to the safer work conditions.

Sumitomo's patented technology of AWC could make the selection of "turning modes" easy in one-touch operation. The modes are; the "stacking mode" that makes the width of a right angled stacking aisle shortest, and the "turning mode" makes the u-turn radius shortest and available for turning on the spot. In the "stacking mode," the machine automatically adapts its center of the turn to the most appropriate steering angle for the shortest turning radius for making the width of the stacking aisle shortest. Because of these functions, the operator could operate the machine turning in the shortest width of "right angled stacking aisle" without minding an appropriate steering angle only by cutting off the steering to the end.

AWC turning mode

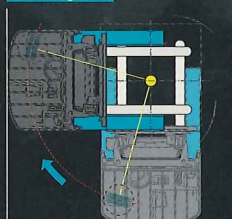

AWC stacking mode

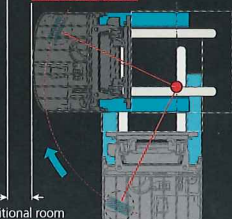

The turning center in AWC turning mode
The turning center in AWC stacking mode

Additional room of the aisle made by stacking mode

Comfortable cabin space for ease of operation

To tap the machine's true performance, maintaining a comfortable cabin where the operator comes into contact is essential. Comfort in getting on and off the cabin space has been enhanced over previous models with meticulous consideration made for the areas where the operator and machine come into contact such as the floor and operation panel.

Comfortable fit for operator Surround cockpit

A round shaped operator space which wraps flexibly around the operator has been adopted while maintaining the easy-to-operate lever type layout. The parts of the operation space which the operator contacts are curved in shape and are designed to provide a natural body fit feel.



The photographs have been shot for the catalog. In actual model, caution labels are adhered to specified areas.

Option



Back support

Option



High-back support

*Shows elbow guard equipped at the same time

Supports operator's body Back support High-back support

A back support (supports the operator's back) and a high-back support (supports the shoulders from the sides) are newly adopted. Support during switchbacks from reverse to forward is provided, and fatigue during normal operation is reduced.



* Shows use of back support

The back support can be adjusted in the vertical direction.



*Shows use of high-back support

Reduction of uncomfortable vibration during travel Low vibration suspension system

The QuaPro-R has adopted a parallel link type structure. Compared to previous models, this structure greatly minimized uncomfortable vibrations from the floor surface, reducing fatigue of the operator. In addition, a suspension lock mechanism has been added to improve stability during turning and load handling, improving both comfort and safety at a higher level.

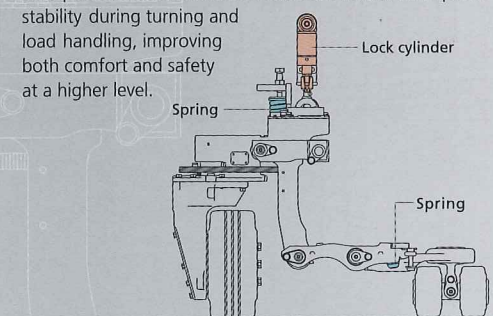

Reduces fatigue during getting on and off Lowered floor

The QuaPro-R has the lowest floor height of 250 mm that tops the industry, -45 mm compare to previous models. This contributes to reduced operator fatigue in reach-forklift truck work with its frequent getting on and off.



250mm
(45mm lower than previous models)

Visor-integrated display

A visor has been newly added to the top of the display to prevent reflected glare and improve visibility. In addition, the display surface is set at an angle facing the operator allowing verification of the display using a natural field of vision.

Equipment and mechanisms for ensuring safety of operators

The QuaPro-R has various safety mechanisms and equipment to ensure the safety of operators during travel and load handling operations. In addition, to ensure the safe operation in high, dark places, various options are available such as LED illumination, a carriage light, and a safety laser.



Option

Elbow guard

Prevents operator's body from protruding Elbow guard

The elbow guard covers the right side of the forklift to prevent the operator from protruding, and protecting the operator from becoming inadvertently pinned.



Restricts dangerous acceleration during turns Turn speed control

The torque of the travel motor is controlled according to the amount of steering operation. As a result, dangerous acceleration is restricted while the forklift is turning, preventing hazardous situations such as rollover. In addition, unnecessary acceleration is prevented, this contributes to energy conservation. The control is optimized according to the amount of steering operation, therefore operability is not sacrificed.



Optimum control of down-slope speed Slope speed limiter

The slope speed limiter, which restricts unwanted acceleration on down-slopes, is standard equipment. The control records the speed when the accelerator pedal is in the neutral position and maintains a constant speed on a down-slope.



Prevents rollback on upslopes Anti-rollback

The anti-rollback mechanism, which prevents the forklift from rolling back when it starts from a stop on an upslope, is standard equipment.

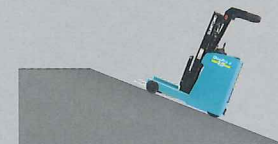

Safety lock during operator's absence Travel and load handling interlock

Travel and load handling operations are locked while the operator is away. The presence or non-presence of the operator is detected by the riding sensor, operation from outside the forklift is locked even when the key is on. While the load handling operations are locked, lift-down operation is locked.



Display during interlock operation

Two optimum controls are combined to provide the highest feeling of safety during starting and stopping.

Front wheel brake anti-skid control

The front-wheel brakes comes into assist if the drive tires slip. This control prevents the tires from been locked and provides maximum brake force, the forklift is stabilized and the braking distance is minimized.

Traction control

Slipping during starts and acceleration is prevented and the optimum traction force is transmitted to the ground. Sway due to slipping is prevented and optimum acceleration is obtained even on a slippery surface.

(These two controls are a set option)

Option



Illumination equipment for safe operation



Option

LED headlight (3-LED type)

The compact headlight does not reduce the visibility and overhead space. An automatic dimming function is not available. (Power consumption: 7.2 W)



Option

LED auto-light (illuminance sensing type)

The 8-LED type light illuminates in a wider area. This environmental-spec illumination automatically dims according to the surrounding brightness. (Power consumption: 19.2 W / 4.8 W (dimmed))



Option

Carriage light

A front light is newly equipped on the carriage. The load (fork insertion point) and rack are directly illuminated, load handling operations can be performed more safely.

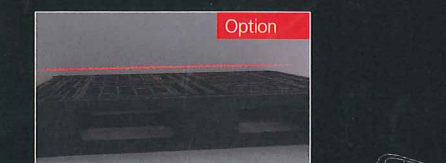

Option

Safety laser

When the forks are detected as being horizontal, horizontal lasers are projected into the insertion holes on the pallet. The operator can determine the fork insertion height accurately and safely. This enhance the efficient of the operation.

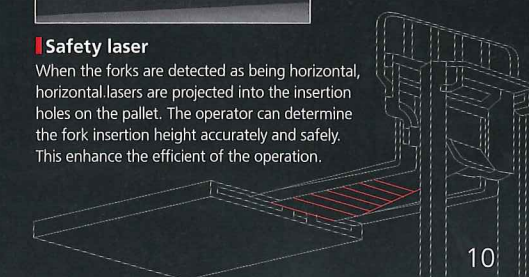

Maintenance cost reduction

The QuaPro-R also fulfills the functions with maintenance. It is designed with consideration for maintenance cost reduction using innovative mechanisms to reduce maintenance-related waste, as well as the addition of various information functions for easy maintenance.

Display

Unified management of simple operations contributes to reduce maintenance cost

Standard display

- Digital clock (alarm function)
- Remaining battery display
- Power mode level display
- Hour meter display (total time/key ON time/travel time)
- Speed limiter setting display
- Forklift operation maintenance data (total time *for 5 days)
- AWC mode display
- Operator setting mode display



Full-function display

Function/display added to standard display

- Digital clock (year, month, date, day/AM, PM/alarm function)
- Hour meter display (total time/key ON time/travel time/load operation time/distance)
- Speed limiter setting display (show set speed)
- Forklift operation maintenance data (total time/battery charge time/travel time/load operation time/distance *for 9 days)

Option

Full-function display-unique options

- Password entry
- PCS (Shock-less load operation, Automatic lift stop, Automatic horizontal stop)

Battery care standard setting by warning display and load operation restriction

BDI interrupt (over-discharge load handling lock)

When the remaining battery is about 20%, a warning message will be shown on the display and the lifting speed is reduced. If the operation is continued, the lifting operation will be stopped to prevent battery over-discharge.

* Recharge the battery immediately when the warning indication is illuminated.

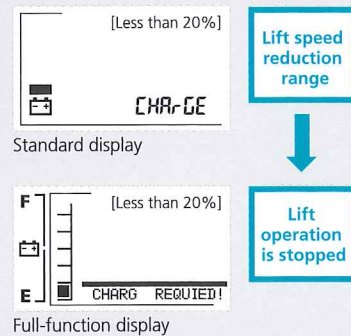

QuaPro-R

Electric Reach Forklift Trucks

Plenty of variations are available.

Select the appropriate model matching the type of work and environment.

Variation



[Photo : 8FBR15C]

Fisheries-use & freezer spec./Other special-spec. models

Fisheries-use spec. model
This type is suitable for operations which handle fishery and water-related products. Highly reliable forklift with enhanced anti-moisture and anti-rust countermeasures provides high resistance against water leakage and rust.
~-10°C

Fishery-product freezer/refrigerator spec. model
This type has a full water/cold resistance mechanism and performs well flexibly in freezers and refrigerators of fishery-processing companies.
~-35°C/~-45°C

Freezer/refrigerator spec. model
This type assures load handling performance, travel performance and energy-conservation effects even under cold temperature conditions, and performs well in freezers and refrigerators of frozen food companies.
~-35°C/~-45°C

Anti-rust spec. model

Anti-dust spec. model

Maintenance

Mechanisms for cost reduction

First adoption of high-efficiency motor on reach forklift truck

IPM motor

Compact and highly efficient **IPM motor** which is also used on electrical automobile, is adopted for the travel motor. The **IPM motor** has high dust-proof performance which eliminates grease shortage malfunctions and contributes in reducing maintenance costs.

Maintenance cost reduction

AC motor for load handling

An **AC motor** is adopted for the load handling motor, its high efficiency contributes to energy conservation. Parts which wear out such as brushes and contactors are unnecessary. This contributes in reducing maintenance cost.

Select the desired battery removal mode based on your maintenance requirements and frequency.

Front battery removal



The battery can be removed by simultaneously operating the key and the battery lock release pedal. Water refilling, inspection and replacement can be performed easily, contributing to reduced maintenance time. Thorough consideration for safety is made such as auto travel-stop while performing maintenance and, of course, mis-operation prevention.

Side battery removal



The battery can be pulled out easily from the side by opening the cover on the side of the vehicle with only a single touch. This also provides flexibility at job sites requiring frequent battery changes.

Specifications		Model/Type/Battery Pullout type		1.0 ton		1.25 ton		1.35 ton		1.5 ton				1.8 ton										
		8FBR10 S(J)XII		8FBR13 S(J)XII		8FBR14 S(J)XII		8FBR15 C(J)XII		8FBR15 S(J)XII		8FBR15 A(J)XII		8FBR15 W(J)XII		8FBR18 S(J)XII		8FBR18 A(J)XII		8FBR18 W(J)XII				
		type S		type S		type S		type C		type S		type A		type W		type S		type A		type W				
Item/Symbol		Front		Side		Front		Side		Front		Side		Front		Side		Front		Side				
Performance	Maximum load capacity	kg	1,000		1,250		1,350		1,500		1,500		1,500		1,500		1,800		1,800		1,800			
	Standard load center	mm	500		500		500		500		500		500		500		500		500		500			
	Standard lifting height	mm	3,000		3,000		3,000		3,000		4,000		4,000		4,000		3,000		4,000		4,000			
	Free lift	mm	113		113		113		113		113		995		995		113		113		995			
	Reach stroke	mm	455		440		595		580		595		580		660		595		770		705			
	Tilting angle (up/down)	deg	G/H		5°/3°		5°/3°		5°/3°		5°/3°		5°/3°		5°/3°		5°/3°		5°/3°		5°/3°			
	Travel speed	(Laden)	km/h	9.5		9.5		9.5		9.0		9.0		9.0		9.0		9.0		9.0		9.0		
		(Unladen)	km/h	11.0		11.0		11.0		10.5		10.5		10.5		10.5		10.5		10.5		10.5		
	Lifting speed	(Laden)	mm/s	360		340		320		310		310		280		280		280		280		250		
		(Unladen)	mm/s	560		560		560		560		560		560		470		560		560		450		
Minimum turning radius (outer)	mm	I		1,360		1,495		1,495		1,580		1,580		1,755		1,755		1,755		1,785		1,755		
Dimensions	Overall length (with fork)	mm	A+K		1,840		1,855		1,920		1,935		1,920		1,935		2,015		2,080		2,080		2,145	
	Overall width	mm	L		1,090		1,090		1,090		1,090		1,090		1,190		1,090		1,090		1,090		1,190	
	Mast lowered height	mm	B		1,995		1,995		1,995		1,995		2,495		1,895		1,995		2,495		1,895		1,895	
	Max mast height w/ backrest	mm	N		3,935		3,935		3,935		3,935		4,935		4,925		3,935		4,935		4,925		4,925	
	Head guard height	mm	M		2,240		2,240		2,240		2,240		2,240		2,240		2,240		2,240		2,240		2,240	
	Step height	mm	S		250		250		250		250		250		250		250		250		250		250	
	Fork length	mm	A		770		850		850		920		920		920		920		920		920		920	
	Fork spread width (maximum)	mm	D		725		725		725		725		725		825		725		725		825		825	
	Fork spread width (minimum)	mm	C		290		290		290		290		290		290		290		290		290		290	
	Wheel base	mm	O		1,110		1,250		1,250		1,340		1,340		1,515		1,515		1,515		1,515		1,515	
	Tread (front/rear)	mm	P/Q		980/640		980/640		990/640		990/640		990/640		1,090/640		990/640		990/640		1,090/640		1,090/640	
	Minimum ground clearance	mm	R		70		70		70		70		70		70		70		70		70		70	
	Vehicle weight	kg			2,035		2,095		2,140		2,225		2,230		2,315		2,335		2,315		2,415		2,435	
	Tires	Front wheel				Rubber; φ255×114		Rubber; φ255×114		Urethane; φ254×102		Urethane; φ254×102		Urethane; φ254×102				Urethane; φ254×102						
		Drive wheel				Rubber; φ330×145		Rubber; φ330×145		Rubber; φ330×145		Rubber; φ330×145		Rubber; φ330×145				Rubber; φ330×145						
Caster wheel					Rubber; φ150×80		Rubber; φ150×80		Rubber; φ150×80		Rubber; φ150×80		Rubber; φ150×80				Rubber; φ150×80							
Electrical components	Travel	Control type			FET inverter		FET inverter		FET inverter		FET inverter		FET inverter		FET inverter									
		Output	kW		4.5		4.5		4.5		4.5		4.5		4.5									
	Hoist	Control type			FET inverter		FET inverter		FET inverter		FET inverter		FET inverter		FET inverter									
		Output	kW		9.6		9.6		9.6		9.6		9.6		9.6									
	Steering	Control type			FET chopper		FET chopper		FET chopper		FET chopper		FET chopper		FET chopper									
		Output	kW		0.3		0.3		0.3		0.3		0.3		0.3									
Rechargeable battery	Voltage × Capacity	V×Ah		48/201		48/201		48/201		48/260		48/280		48/280										

*Front : Front battery removal
Side : Side battery removal

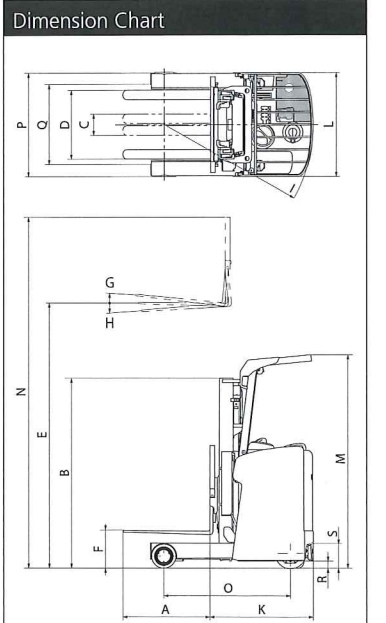

Load Capacity Charts

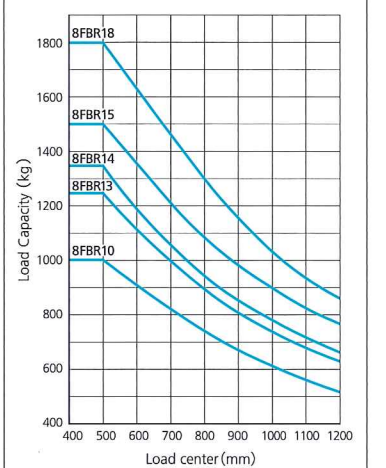

Main Accessories

	Standard specs / accessories	Optional specs / accessories		Standard specs / accessories	Optional specs / accessories
Hoist related	Hoist AC motor	Lift / tilt / reach-speed limiter	Safety	Neutral start	Elbow guard
	Soft landing	PCS *1		Slope speed limiter	Rear rubber bumper
	High-visibility wide mast	Simple load weight scale		Anti-rollback	Rear bumper (floor elongation shape)
	Suspension lock control	Large diameter steering wheel		Volume adjustable type reversing buzzer	Forward / back movement chimer
Steering related	AWC (small radius turning control)		Economy	LCD display	Forward / back melodic chimer
	Small diameter steering wheel			Display *2	Full function display (Full-dot LCD)
	Travel IPM motor	Speed limiter		Battery	Spare battery
	Neutral brake switchback regeneration	Head guard low overall height type			BDI interrupt (stop hoisting at over discharging)
Lamp related	Travel speed/power adjustment/speed limiter		Environmental specs.	Auto power off	Battery carrier
	Headlights	LED headlights			Fisheries use spec. (Up to -10°C)
	Turning indicators	LED auto lights (light sensitive type)			General freezer refrigerator spec. (Up to -35°C / -45°C)
		Safety laser			Fisheries use freezer refrigerator spec. (Up to -35°C / -45°C)
		Carriage light			Anti-rust spec.
		LED rotating light			Anti-dust spec.
		LED work light			
		LED room light			

*1: Performs shock-less start to finish loading/unloading, auto-stop at maximum height, and horizontal auto-stop.
*2: For the standard display/full function display function details, refer to the Cost Efficiency page (page 11).

Mast

	1.0 ton		1.25 ton		1.35 ton		1.5 ton						1.8 ton									
	8FBR10S		8FBR13S		8FBR14S		8FBR15C		8FBR15S		8FBR15A		8FBR15W		8FBR18S		8FBR18A		8FBR18W			
	type S		type S		type S		type C		type S		type A		type W		type S		type A		type W			
Max. lifting height (mast designation)		Standard	Semi-free	2 Full-free	3 Full-free	Standard	Semi-free	2 Full-free	3 Full-free	Standard	Semi-free	2 Full-free	3 Full-free	Standard	Semi-free	2 Full-free	3 Full-free	Standard	Semi-free	2 Full-free	3 Full-free	
	2,500																					
	2,700																					
	3,000																					
	3,300																					
	3,500																					
	3,700																					
	4,000																					
	4,300																					
	4,500																					
	4,700																					
	5,000																					
	5,500																					
6,000																						
6,500																						
7,000																						
7,500																						

Special order will be needed for the product with the mast lifting over 6,000, please feel free to contact us for detailed information.

Battery

Battery capacity	1.0 ton		1.25 ton		1.35 ton		1.5 ton						1.8 ton									
	8FBR10S		8FBR13S		8FBR14S		8FBR15C		8FBR15S		8FBR15A		8FBR15W		8FBR18S		8FBR18A		8FBR18W			
	type S		type S		type S		type C		type S		type A		type W		type S		type A		type W			
201Ah / 5h (48V)																						
260Ah / 5h (48V)																						
280Ah / 5h (48V)																						
340Ah / 5h (48V)																						
370Ah / 5h (48V)																						

*Front : Front battery removal
Side : Side battery removal